

KNAUF



Build on us.

***Knauf Frameless
Encasement Solutions***
Fire Protection for Structural Steel



RIACHUELO

Av. Paulista

RIACHUELO



CONTENTS

- 04 Introduction to Passive Fire Protection**
- 06 Knauf Frameless Encasement Solutions**
- 08 Knauf Frameless Encasement Range**
- 09 Components**
- 12 Calculation for Board Thickness and Layers**
- 14 Determination of Profile Factor A/V**
- 16 Installation Guides**
- 17 Beam Encasements**
- 18 Column Encasements**
- 19 Stapling**
- 20 Fillets**
- 21 Wall Connections**
- 22 Material Requirements**
- 24 Installation Guides - Construction, Application, Jointing and Coating**
- 28 Sustainability**
- 30 CITB Accredited Training Organisation**
- 31 Courses Available**

Introduction

PASSIVE FIRE PROTECTION

Whilst we hope it's never required, passive fire protection is a critical component for fire safety in buildings. Most importantly, it helps protect the lives of anyone using the building, but it can also reduce the financial impact of damage to buildings and contents if a fire does breakout.

Protection of structural steel is of paramount importance, the whole buildings structural stability relies on the systems integrity being maintained, especially in the event of a fire.

Structural steel loses strength in terms of its stability around the 550°C although this will vary depending on project requirements, so systems that protect the structural steels from the excessive heat associated with fire, are vital.

Glass Reinforced Gypsum (GRG) boards are widely used for structural fire protection in the

UK and Ireland. They are used both when the protection system is in full view and where it is concealed. GRG boards give a clean "boxed" appearance, with the added advantage that the installation is a dry trade meaning it is less likely to have significant impacts on other build programme activities. Boards also offer the security of guaranteed thicknesses and performance due to the manufacturing process.

Knauf's Frameless Encasement system provides fire protection to structural columns and beams. It can be finished with a number of coatings and linings, including Knauf Airless Finish to match adjoining elements. The coatings do not affect the fire resistance classification of the system.



Knauf Frameless Encasement Solutions

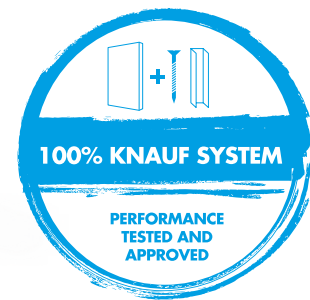
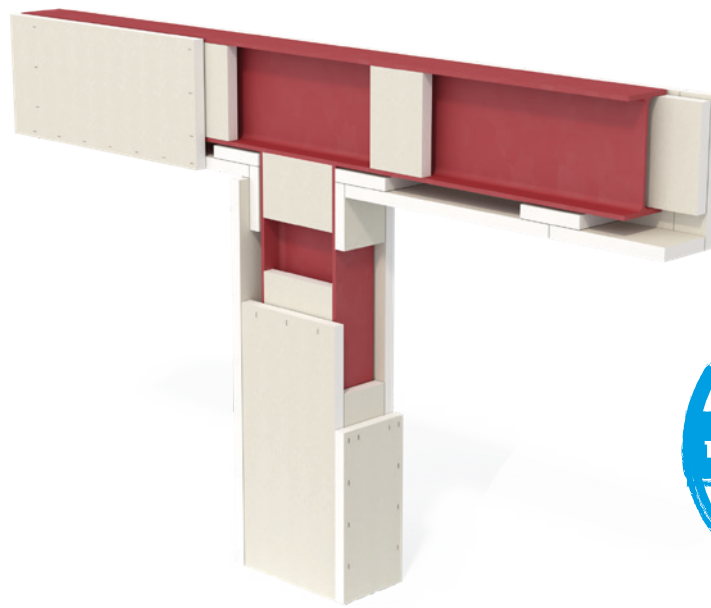

Knauf Frameless Encasement Solutions using Knauf Fireboard, have been specifically developed to create encasements of column and beam structural steel work.

Frameless casings simply consist of Knauf Fireboard stapled to itself at abutting corners. For steelwork encased on all four sides, Knauf Fireboard is fixed at each corner directly through the material, independent of the structural steel. For partial encasements, involving wall or ceiling abutments, the encasement is fixed using lightweight Knauf Angle Sections at the abutment.

Key Features:

- Knauf's Frameless Encasement System maximises the sellable floor space of the building
- Covered by Knauf's full system performance warranty
- Gives a range of fire protection performance from 30-240 minutes to a wide range of beam, column and joist sizes
- Reduced installation time as Knauf Fireboards can be stapled to one another without the need for other components
- Inspections for continuity are easier with the Knauf Frameless Encasement system compared to intumescent paint solutions, giving greater peace of mind both immediately after installation and during maintenance inspections
- The boards have a high quality smooth surface finish, and can be taped, jointed and finished using Knauf Fireboard Spachtel (Joint Filler) and accessories



Frameless encasement systems have multiple benefits:



Provide up to four hours' fire protection



Speed and ease of installation



The boards have a high quality smooth surface finish, and can be taped, jointed and finished using Knauf Fireboard Spachtel (Joint Filler) and Accessories

KNAUF FRAMELESS ENCASEMENT RANGE

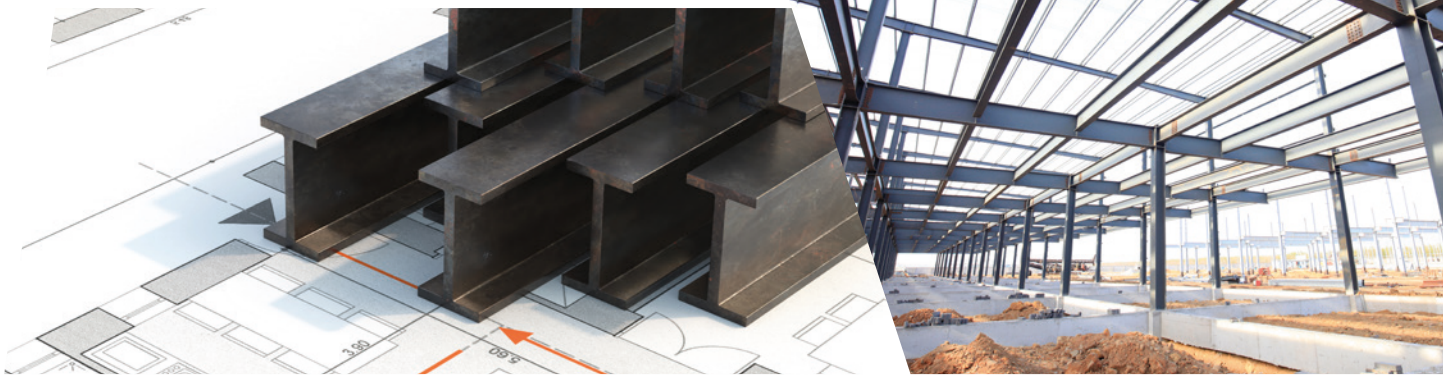

Knauf Frameless Encasement Range consists of:



Knauf Fireboard



Knauf Fireboard-Spachtel (Joint Filler and Finish)



Knauf Glasfaser-Fugendeckstreifen (Joint Tape)



Knauf Hartmut (Fixing)

Please note: The Knauf Hartmut fixing is not part of the Frameless Encasement. It is an additional component to connect two systems together. Encasement and Partitions/linings.

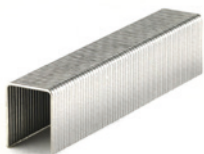

Staples (available from others)

COMPONENTS

Knauf Fireboard

Knauf Fireboard is a fleece-lined, glass reinforced gypsum (GRG) board, available in a range of thicknesses to suit all installation requirements.

Knauf Fireboard is also ideal for use as fillets in deflection head details.



A1 Reaction to Fire

Provides up to 4 hours fire protection for structural steel encasement.

Reaction to fire A1, according to EN 13501-1 of type GM-F according to EN 15283-1.

No need for additional coatings on the structural steel.



Available in 15, 20, 25 and 30mm

Various thicknesses and number of layers can provide various levels of fire protection performances.

No need to over engineer a design, simply use different board thickness combinations to achieve the required fire rating.



Ease of installation

No specialist labour or installation methods required.

No waiting for coatings or paint to dry in adverse weather conditions.



JOINT FILLER

Knauf Fireboard-Spachtel

Knauf Fireboard-Spachtel is a gypsum-based powder that is mixed with water to form a pliable joint filler.

Knauf recommend that Fireboards must be tightly butted. Joint filler is required for bedding joint tape. On exposed encasements, Knauf Fireboard-Spachtel can also be used as a finish, providing a smooth surface for decoration if required.

Quality Assured

Manufactured in compliance with EN 13963.

Shelf Life

Can be stored for up to 6 months.

Workable Time

Apply Knauf Fireboard-Spachtel within 45 minutes of mixing.

Mixing

Sprinkle a maximum of 2.5kg into approx. 2 litres of cold water and mix to a lump-free creamy texture with a trowel or other similar hand tool.

JOINT TAPE

Knauf Glasfaser-Fugendeckstreifen

Knauf Glasfaser-Fugendeckstreifen is a fibre-glass tape used on all joints in Knauf Frameless Encasement installation.

To be embedded in Knauf Fireboard-Spachtel.

Handy Rolls

Available in 25m long rolls of 50mm wide.

FIXINGS

Knauf Hartmut

Knauf Hartmut is the ideal fixing through the Knauf partition stud to an abutting Knauf Frameless Encasement system.

Fixings included

The fixing includes a M5 x 60mm screw.

Staples

Knauf Fireboard is assembled around beams and columns using staples to fix board to board.

Staples used are to DIN 18182 or EN 14566 with steel wire diameter $\geq 1.34\text{mm}$ and are available from others.



CALCULATION FOR BOARD THICKNESS AND LAYERS



Knauf Fireboard is available in 15mm, 20mm, 25mm and 30mm thicknesses that can be combined to meet the performance requirements of the installation.

The below example shows a typical calculation. Knauf recommends that the ASFP yellow book is used for A/V factors, or a structural engineer completes the necessary calculations.

Example

Requirement: One hour fire protection to 457mm x 191mm x 98kg/m steel beam with three-sided encasements. Refer to page 14 for details of formula used.

Solution: Section factor $A/V = 90\text{m}^{-1}$. Use single layer of 15mm Fireboard.

Section factors for Universal Columns

Section size (mm)	Mass per metre (kg)	3 sides A/V (Hp/A) (m^{-1})	4 sides A/V (Hp/A) (m^{-1})
356 x 406	634	15	20
	551	20	25
	467	20	30
	393	25	35
	340	30	35
	287	30	45
356 x 368	235	40	50
	202	45	60
	177	50	65
	153	55	75
305 x 305	129	65	90
	283	30	40
	240	35	45
	198	40	50
254 x 254	158	50	65
	137	55	70
	118	60	85
	97	75	100
	167	40	50
	132	50	65
203 x 203	107	60	75
	89	70	90
	73	80	110
	86	60	80
	71	70	95
	60	80	110
152 x 152	52	95	125
	46	105	140
	37	100	135
	30	120	160
152 x 152	23	155	210

Section factors for Universal Beams

Section size (mm)	Mass per metre (kg)	3 sides A/V (Hp/A) (m^{-1})	4 sides A/V (Hp/A) (m^{-1})
914 x 419	388	45	55
	343	50	60
914 x 305	289	60	65
	253	65	75
	224	75	85
	201	80	95
838 x 292	226	70	80
	194	80	90
	176	90	100
762 x 267	197	70	85
	173	80	95
	147	95	110
686 x 254	170	75	90
	152	85	95
	140	90	105
	125	100	115

Section factors for Universal Beams (cont.)

Section size (mm)	Mass per metre (kg)	3 sides A/V (Hp/A) (m^{-1})	4 sides A/V (Hp/A) (m^{-1})
610 x 305	238	50	60
	179	70	80
	149	80	95
610 x 229	140	80	95
	125	90	105
	113	100	115
	101	110	130
533 x 210	122	85	95
	109	95	110
	101	100	115
	92	110	125
	82	120	140
457 x 191	98	90	105
	89	100	115
	82	105	125
	74	115	135
	67	130	150
457 x 152	82	105	120
	74	115	130
	67	125	145
	60	140	160
	52	160	180
406 x 178	74	105	125
	67	115	140
	60	130	155
	54	145	170
406 x 140	46	160	185
	39	190	215
	356 x 171	67	105
57		120	145
51		135	160
45		150	180
356 x 127	39	165	195
	33	195	225
305 x 165	54	115	140
	46	135	160
	40	150	185
305 x 127	48	120	145
	42	140	160
	37	155	180
305 x 102	33	175	200
	28	200	230
	25	225	255
254 x 146	43	120	150
	37	140	170
	31	165	200
254 x 102	28	175	200
	25	190	225
	22	220	255
203 x 133	30	145	180
	25	170	210
203 x 102	23	175	205

Note: Tables from 4th edition Yellow Book, Structural Steel in Building

Board Thickness Combinations by Performance Requirement

Section Factor (A/V)	Minutes*					
	30	60	90	120	180	240
10	15mm	15mm	15mm	20mm	30mm	25+20mm
20						
30						
40						
50						
60						
70					25+20mm	
80			20mm	25mm		
90						
100				30mm		
110						
120			25mm			
130				20+20mm		
140						
150		20mm				
160						
170			30mm			
180						
190				25+20mm		
200						
210						
220						
230			20+15mm			
240						
250						
260						
270		25mm				
280						
290						
300						
310						
320						
330						
340			20+20mm			
350						
360						
370						
372.5						

Structural and fire protection specialists to review and provide A/V sections factors in accordance with industry structural steel guidance's.

*Note: Limiting temperature of a structural steel member at 550°C

DETERMINATION OF PROFILE FACTOR A/V



$$\text{Profile factor } A/V \text{ [m}^{-1}\text{]} = \frac{\text{Inner circumference } A \text{ of the encasement [cm]}}{\text{Profile cross-section } V \text{ [cm}^2\text{]}} \times 100$$

Examples for the determination of the inner circumference A of the encasement and the profile cross-section V.

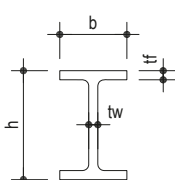
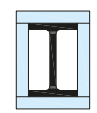
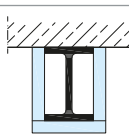
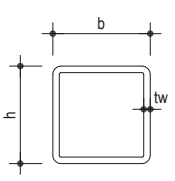
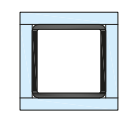
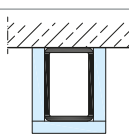
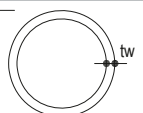
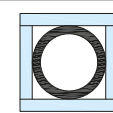
Steel Profile		Profile cross-section V in cm ²	Fire exposure	Inner circumference A of the encasement in cm
I profile or H profile		$tw \cdot (h - 2tf) + 2 \times (b \times tf)$	4-sided	 $2b + 2h$
			3-sided	 $b + 2h$
Square or rectangular hollow profile		$2tw \times b + 2tw \times (h - 2tw)$	4-sided	 $2b + 2h$
			3-sided	 $b + 2h$
Circular hollow profile		$\pi \times (d/2)^2 - \pi \times [(d - 2tw)/2]^2$	4-sided	 $\pi \times d$

Specification of d, b, h, tw and tf in cm.

Please note: These calculations should be completed by a structural engineer.



IPE: Hot-rolled, medium flange I-sections

HEA: Hot-rolled, wide flange I-sections, light design

HEB: Hot-rolled, wide flange I-sections

HEM: Hot-rolled, wide flange I-sections, heavy design

Valid for IPE, HEA, HEB, HEM sections up to 600mm.

- Permissible span width of boarding $\leq 600\text{mm}$ ($\leq 500\text{mm}$ for Fireboard 15mm)
- For beam heights $>600\text{mm}$, a substructure is required. Please use the Knauf framed encasement system, to support the Horizontal board joint between boards.
- The required board thickness "t" depends on the required fire resistance and the A/V ratio of the steel beam section. See page 13 for board thickness requirements
- Joint backing required with single-layer board, to support the Horizontal board joint between boards
- Staple all board layers with steel staples to DIN 18182 or EN 14566 with backing strips made of Knauf Fireboard. Please refer to page 19 for staple installation specification

Valid for open I, T, U and L-shaped roller profiles or for profiles of compound sections with parallel flange.

- In case of single-layer encasement, back with Knauf Fireboard strips of thickness "t" (min. 25mm), width 150mm on the board joint
- In case of 15mm board encasement thickness, Fireboard strips with "t" of min 20mm is sufficient. 20mm Board is required to support all board joints, this applies to a single 15mm Layer system.
- Staple all board layers with steel staples acc. to DIN 18182 or EN 14566 with steel wire diameter 1.34mm with backing made of Knauf Fireboard strips as well as in the face side in the corners. Please refer to page 19 for staple installation specification.

BEAM ENCASEMENTS

Joint Backing

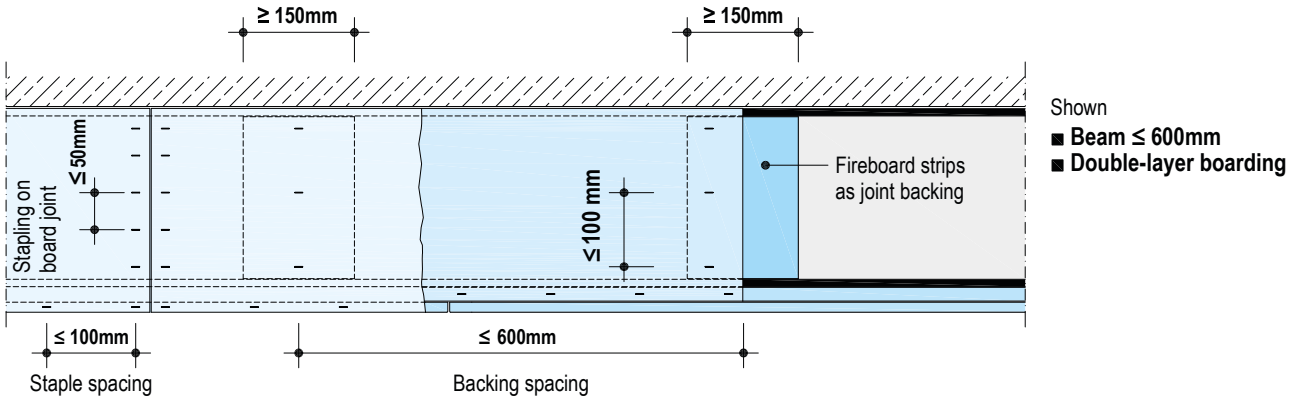

Single Layer Frameless Encasement Cross Section

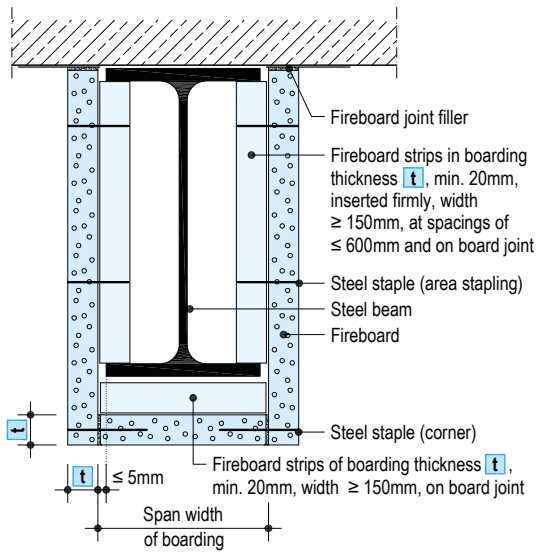

Double Layer Frameless Encasement Cross Section

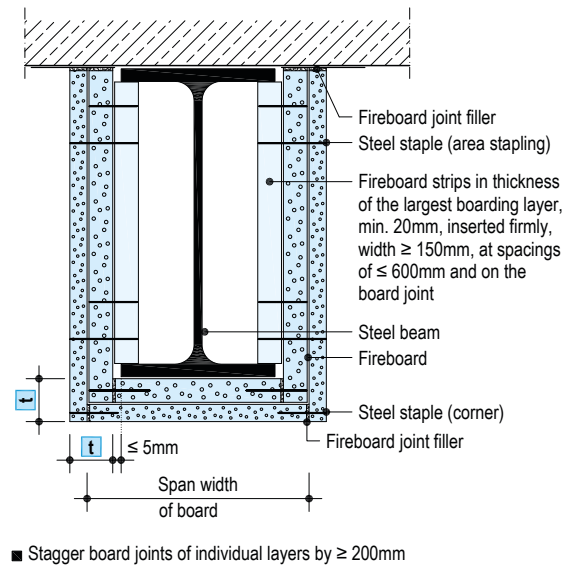

Single-layer boarding

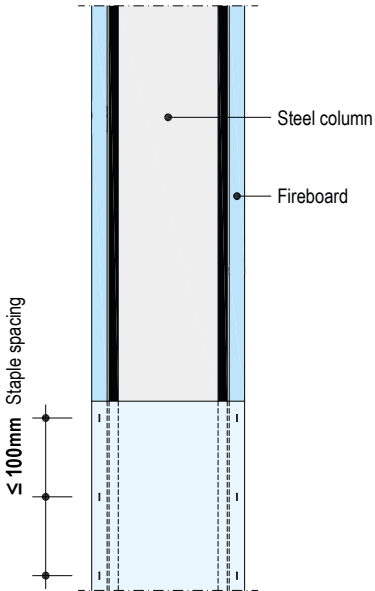

Horizontal cross section - single layer boarding

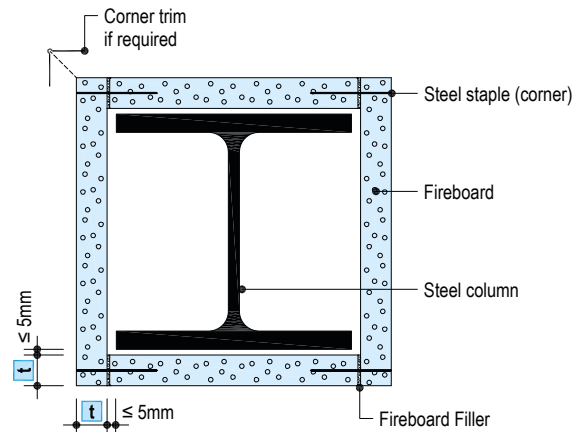

Note: This detail is only suitable up to 1800mm high

Double-layer boarding

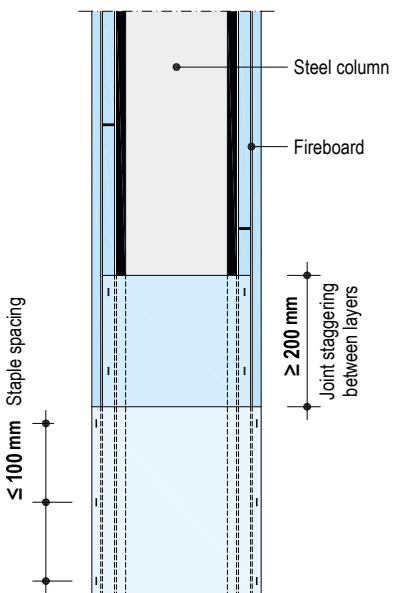

Horizontal cross section - double layer boarding

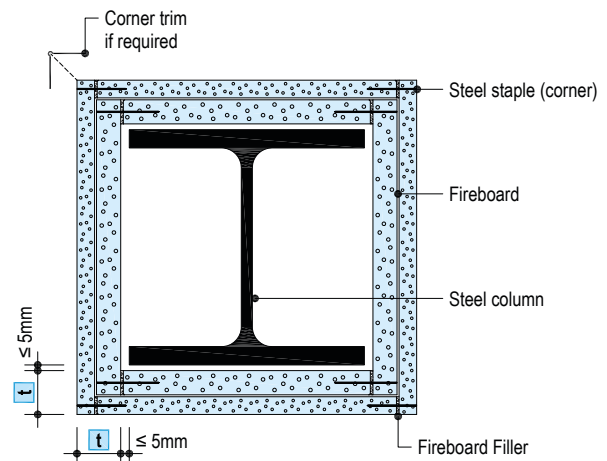

Flush stapling of the board

Fireboard thickness mm	Fireboard strips mm	Staple lengths mm	Max staple spacings mm
15	20	35	100
20	25	40	100
25	25	50	100
30	30	60	100
20 + 15	25	40 + 55	100
2 × 20	25	40 + 60	100
25 + 20	25	50 + 70	100
2 × 25	25	50 + 75	100

Front side stapling of the board

Fireboard thickness mm	Stapling lengths mm	Max. staple spacings mm
15	40	100
20	50	100
25	64	100
30	75	100
20 + 15	50 + 40	100
2 × 20	50 + 50	100
25 + 20	64 + 50	100
2 × 25	64 + 64	100

- The required board thickness "t" depends on the required fire resistance and the U/A rate of the steel column section.
- Staple all board layers with steel staples to DIN 18182 or EN 14566 with steel wire diameter $\geq 1.34\text{mm}$
- Permissible cladding span width $\leq 600\text{mm}$

Steel beam frameless encasement, stapled with Fireboard strips

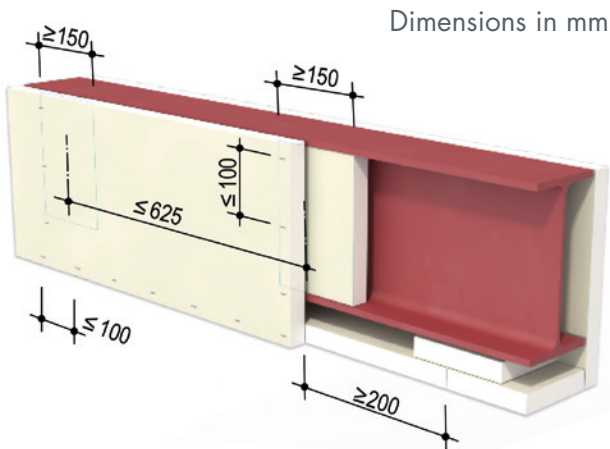

- Friction fit Fireboard strips between the steel beam flange, "t" minimum 20mm (with 15mm board thickness, strips at least 20mm thick are sufficient) and width ≥ 150 mm on the board joint and as backing, with a spacing of maximum 600mm
- To make the insertion easier, the Fireboard strips can be cut with a sloped face and jammed in with the assistance of the sloped cut

Steel column frameless encasement, stapled with Fireboard strips

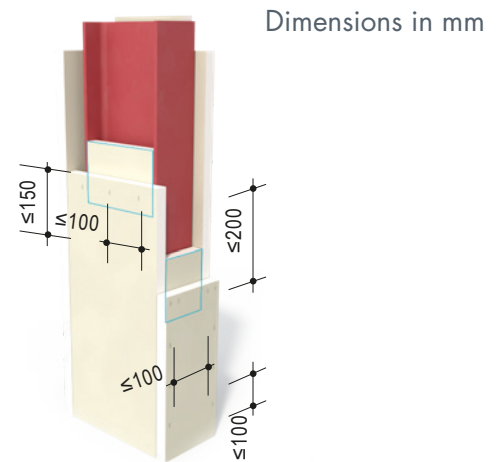

- In case of single-layer board encasement, back with Fireboard strips of thickness "t" minimum 20mm and width ≥ 150 mm on the board joint. In case of 15mm board thickness, Fireboard strips with "t" of minimum 20mm are sufficient
- Staple all board layers with steel staples to DIN 18182 or EN 14566, with steel wire diameter ≥ 1.34 mm, with backing made of Fireboard strips as well as in the face side in the corners
- Stagger the board joints by ≥ 200 mm with multi-layer boarding

Fireboard Strips
Type A two-part

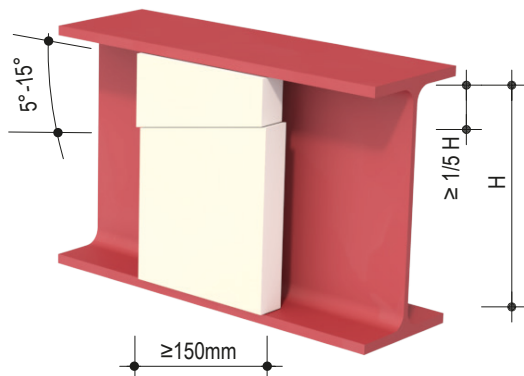

Fireboard Strips
Type B one-part

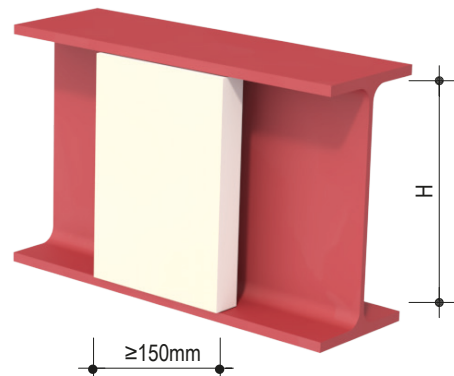

WALL CONNECTIONS

Wall connection (steel column)

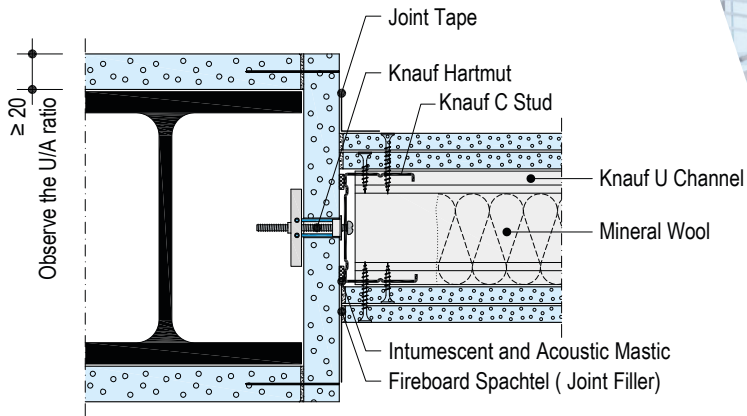

Application with trapezoid metal sheet

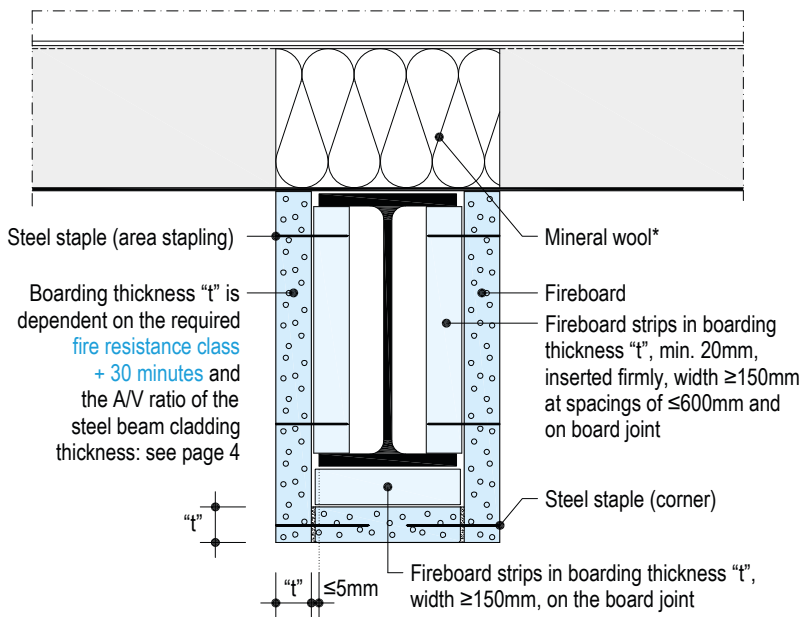

* **Recommendation:** Fire protection mineral wool [consultation by supplier of product required] to maintain performance of detail.

MATERIAL REQUIREMENTS

The following guides show the typical quantity of product needed for Knauf Frameless Encasement systems when installed.

Material requirement per m Fireboard encasement

Without allowance for loss and waste

- not provided by Knauf = printed in italics

Steel beam frameless encasement

- ① 3-sided, without substructure

Steel beam IPE 240 4500mm long 25mm Fireboard stapled

Steel column frameless encasement

- ② 4-sided, without substructure

Steel column HEB 140 3500mm long 25mm Fireboard stapled

Description	Unit	Quantity as average value	
		①	②
Boarding			
Fireboard 25mm (board strips)	m ²	0.17	0.12
Fireboard 25mm	m ²	0.75	0.9
Stapling (See respective system for required lengths)			
Steel staples - surface stapling	pcs	24	16
Steel staples - corner stapling	pcs	19	37
Jointing			
Fireboard Spachtel (Joint Filler)	kg	0.85	0.85
or Fireboard Spachtel (Joint Filler + 1 mm surface skim coat)	kg	1.1	1.2
or Fireboard Spachtel (Joint Filler + 3 mm surface skim coat)	kg	2.65	3.0





INSTALLATION GUIDES - CONSTRUCTION, APPLICATION, JOINTING AND COATING

The following guide provides how the Knauf Fireboard Frameless Encasement System should be installed.

Construction

Fire protection encasements of steel beams and columns using Knauf Fireboard are possible up to fire protection of 240 minutes.

Knauf Fireboards are special A1 glass reinforced gypsum boards for fire protection, type GM-F acc. to EN 15283-1.

Knauf Fireboard is available in thicknesses of 15, 20, 25 and 30mm.

Fireboard Steel Beam and Steel Column Encasements are made of Fireboard strips without substructure.

Application

Steel Beam and Column Frameless Encasement

- Insert Knauf Fireboard strips ("t" ≥ cladding thickness, min. 20mm, b ≥ 150mm) firmly between steel beam flanges or lay them on the bottom side as backing (with single board cladding) or at board joints at a spacing of max. 600mm
- Fasten the Knauf Fireboards on the board strips and at corners by means of staples at a spacing of ≤ 100mm, or at spacings ≤ 50mm at board joints. Use steel staples acc. to DIN 18182 or EN 14566
- Stagger the board joints by ≥ 200mm



Jointing

Knauf Fireboard-Spachtel and Knauf Glasfaser-Fugendeckstreifen (joint tape) are both used to fill Knauf Fireboard joints and to create a smooth surface finish if required for subsequent decoration.

Application

- Fill all board joints of outer board layers with Knauf Fireboard-Spachtel (Joint Filler) and embed Knauf Glasfaser-Fugendeckstreifen (Joint Tape)
- Fill in visible staples with Knauf Fireboard-Spachtel (Joint Filler)
- As a substrate for direct lining or coating, additional skimming of the entire surface with Knauf Fireboard-Spachtel (Joint Filler) is recommended
- The use of corner trims are recommended for columns

Connection Joints

Whilst board joints are tightly abutted should a gap of 3mm or greater be evident then fill using spachtel to ensure the board joint is sealed.

Application temperature / climate

- Filling and covering of joints should only take place when no more longitudinal changes can be expected, i.e. expansion or contraction due to humidity or temperature changes
- Do not apply filling at room or substrate temperatures below +10°C
- In case of mastic asphalt screed, cementitious screed and self-levelling screed, fill in board joints after screed has been applied





Pretreatment

- Before further coating or lining is applied, the filled surface must be free of dust
- Ensure that the primer and the subsequent paint / coating / lining are compatible
- In order to compensate for the differences in absorption of surfaces, a coating of Knauf Fireboard-Spachtel is required

Suitable coatings and linings

- Wallpapers
- Paper, fleece, textile and synthetic wallpapers
Use only adhesives made of methyl cellulose
- Plaster and filler materials
- Top coats (e.g. Knauf Airless Finish)
- Full surface skimming (e.g. Knauf Fireboard-Spachtel)
- Dispersion paint
- Silicate-based emulsion paints with suitable primer
- Emulsion

Unsuitable coatings and linings

- Alkaline coats such as lime, water glass paints and silicate-based paints, without a suitable primer

Notes

After wallpapering or after application of plasters, quick drying must be ensured through adequate airing. Other coatings or layers and vapour barriers up to about 0.5mm thickness as well as claddings (with the exception of sheet steel), do not have any influence on the technical fire resistance classification of Knauf Fireboard Steel Column and Beam Encasements.

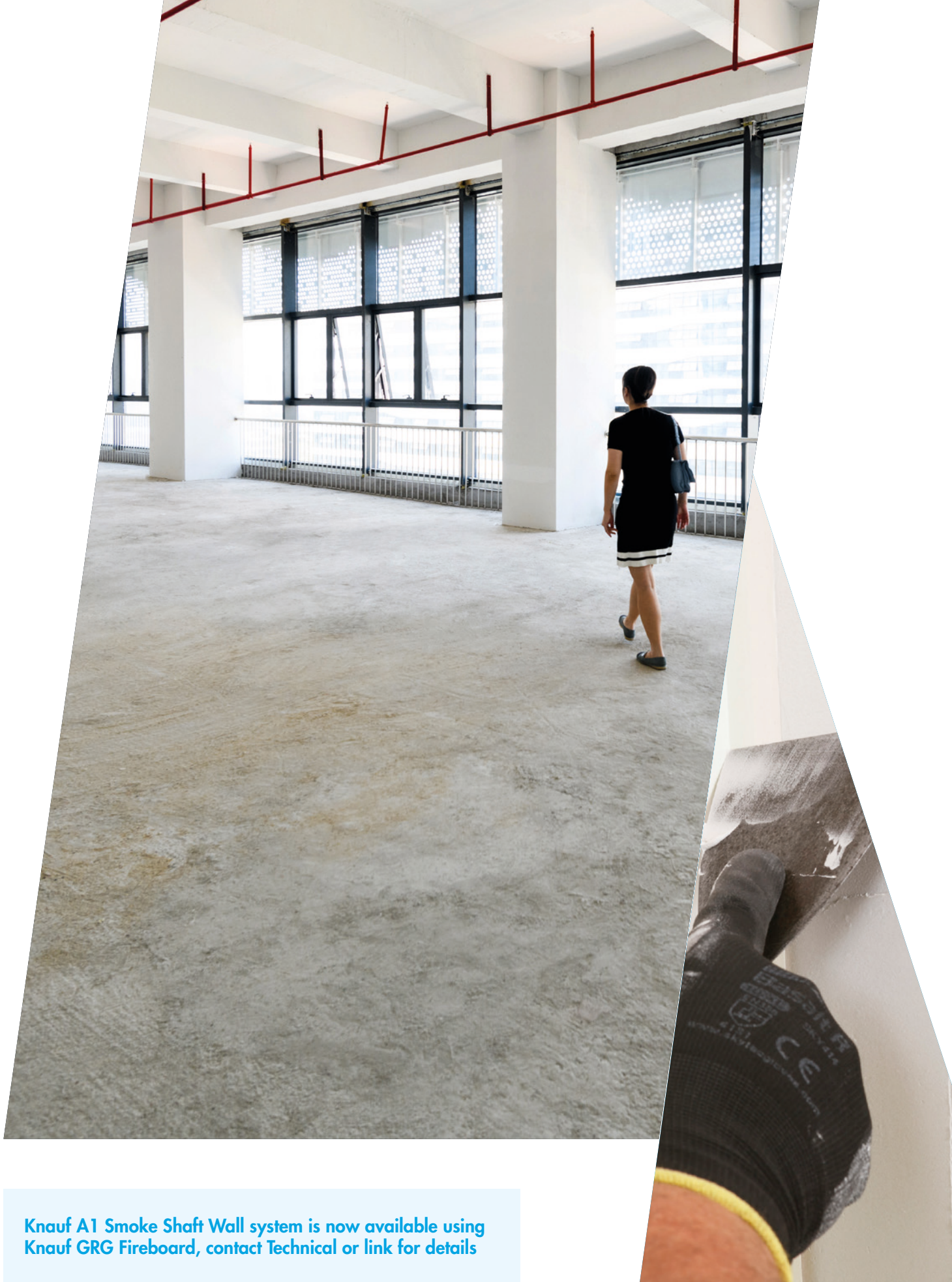

Knauf A1 Smoke Shaft Wall system is now available using Knauf GRG Fireboard, contact Technical or link for details

SUSTAINABILITY

Knauf is committed to build a more sustainable world.

We are working to ensure that our People, Planet, Prosperity strategy is considered in all areas of our business where we have an influence. We are reducing our carbon footprint, improving the recycled content of our products, taking care of our people and increasing our social value. Every Knauf product contributes to sustainability in its own way – please see details of this product below.

LEED

Building assessment systems ensure the sustainable quality of buildings and constructional structures by a detailed assessment of ecological, economic, social, functional and technical aspects. The certification systems of LEED (Leadership in Energy and Environmental Design) are of particular relevance.

Knauf Fireboard Beam and Column Encasements can positively influence many of these criteria.

LEED - Materials and resources

- Credit: Recycled content
- Recycled content in Fireboard Spachtel (Joint Filler)

Knauf Sustainability

- Quick to construct. Time saving installation method, removing the need for subframe installation makes this system inherently quicker to install
- Simple to install. Uses standard dry lining methods and site tools for installation
- Slim construction. Achieves greater saleable floor space without detriment to performance and protection of the structural elements of a building
- No hazardous chemicals. The products are not hazardous, boards are easily cut and installed with minimal dust
- Recyclable. Allowing a closed loop approach which is better for the environment

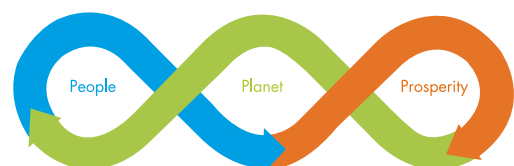





CITB Accredited Training Organisation

The Learning Zones at Immingham and Sittingbourne are CITB approved training facilities and offer various courses for the construction industry. We believe in future-proofing and protecting the workforce.

We build for the world we live in.



We provide the best possible training on the large variety of systems and products that we supply, and make our courses widely available to those who request them. Whether the trainees are already skilled tradespeople, wishing to add to their existing knowledge, or people with no previous experience, there is a course in our range to benefit all.

We are happy to advise on the suitability of different courses and the content can be adapted to suit the requirements of the delegates.

All work carried out on the Knauf courses will be in a simulated site environment, and to industry standards, using British Standard and European Codes of Practice for accuracy and finish.

Contact us to find out more about the latest courses available.

Courses available

Drylining – Direct bonding and metal lining systems

Fire protection – Encasement systems

General overview of interior products and systems

Metal stud partitions, shaft wall, wall linings

Metal suspended ceiling systems

Flooring – Brio and GIFA systems

Façades – Steel framing systems

Taping and jointing

Renders and external wall insulation (EWI)

Demountable ceiling systems

Drywall for site managers / Quality Control

Airless spray finishing

TELEPHONE

01795 424499

EMAIL

training@knauf.co.uk

WEBSITE

knauf.co.uk and knauf.ie





Customer Service

UK: 0800 521 050

Eire: 01 4620739

cservice@knauf.com

Technical Service

0800 521 050 (press option 2)

Live Webchat 09:00 – 17:00

technical-uk@knauf.com

(excluding bank holidays)

Website

knauf.co.uk

knauf.ie

Addresses

Knauf

Kemsley Fields Business Park

Sittingbourne

Kent ME9 8SR

Knauf

87 Broomhill Road

Tallaght

Dublin 24

D24 WR85

Social Media

 /KnaufUK

 KnaufUK

 Knauf UK & Ireland

 @Knauf_UK

The information given in this publication is believed to be current and accurate as at the date of publication, but no warranty, express or implied is given.

Updates will not be automatically issued.

© Copyright Knauf 2024



KNAUF

Build on us.