



Innovative unit-dose packaging



V-SHAPES® COMPLETE MACHINES OFFER



FOOD



COSMETIC



MEDICAL/PHARMA



CHEMICAL



V-Shapes® Innovative unit-dose packaging

The only patented single pack easy to open with just one hand

With a constantly evolving machine park and always looking for greater automation and integration with the printing phase, V-Shapes® automatic packaging machines boast made in Italy components of the highest quality and, thanks to augmented reality systems and modern technologies, they can be installed and managed remotely as well.

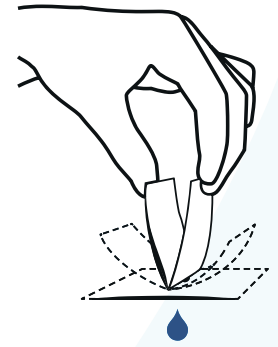

V-Shapes® sales point around the globe

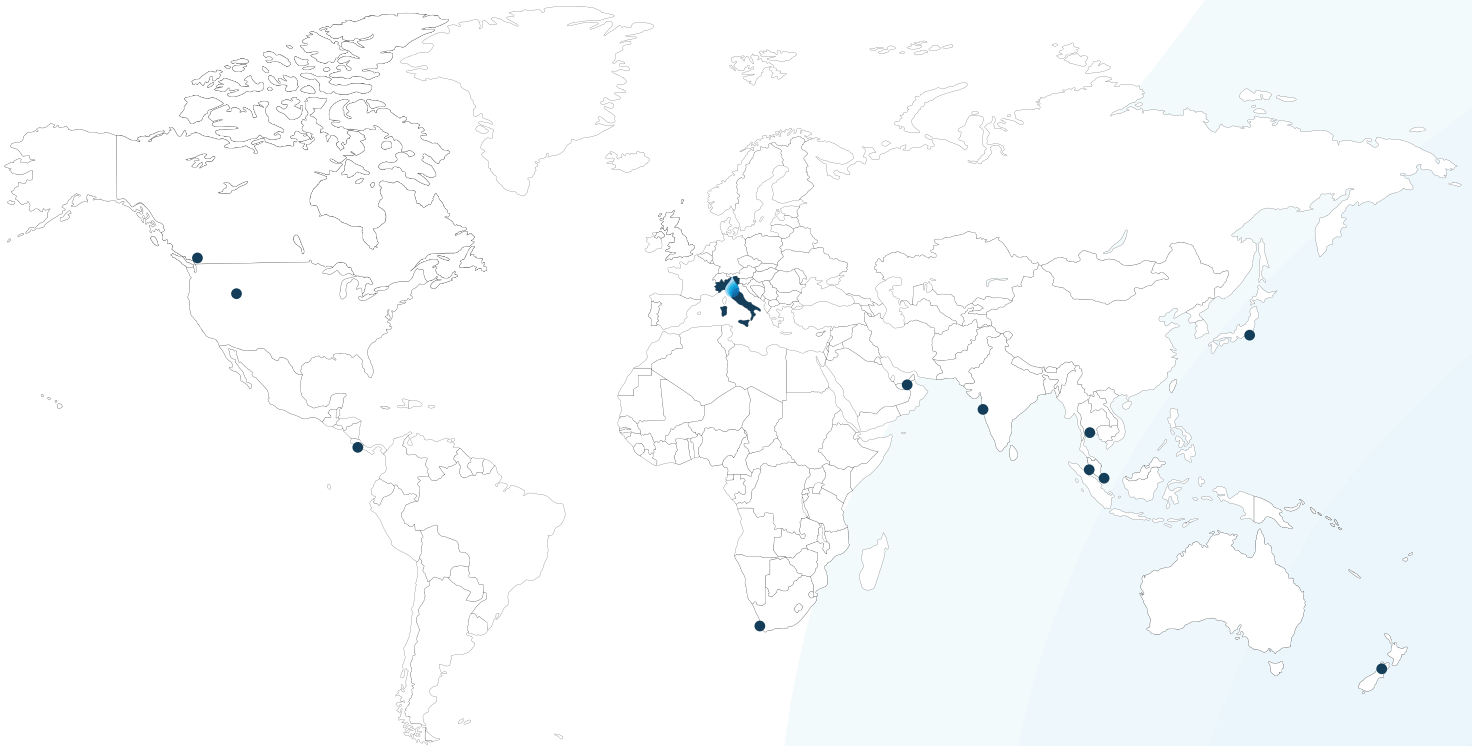

Special partners to innovate together



Converting machines

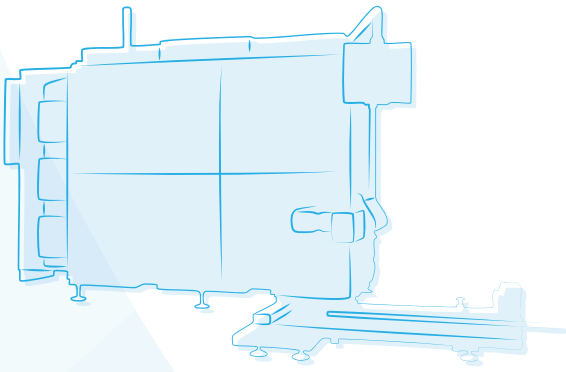

alpha

Our best selling machines, **Alpha**, is the first born and patented in V-Shapes® Headquarter in Bologna. Thanks to the extreme adaptability to any kind of product, fluids, creams or granular and the high production volumes it's the perfect choice for any brands, converters and co-packers.

Prime

Prime is our latest single lane automated fill, form and seal machine, which is particularly suitable to run small to medium production with a minimum footprint and higher ROI.

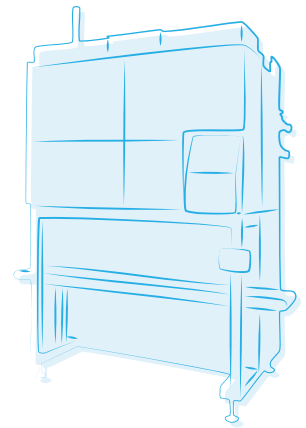

Printing machines and printing integrations

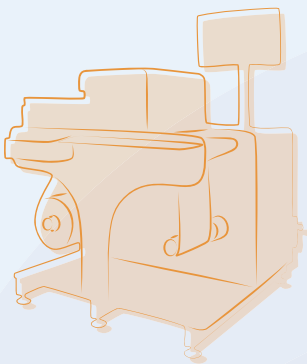

VSdflex

VS dflex is a powerful compact single pass print unit integrable with V-Shapes® packaging machines, which allows to print and pack the unit-dose sachets on both their layer, top and bottom side, decreasing cost, time to market and space necessary for productions.

alpha
Flex

AlphaFlex is the latest innovation in V-Shapes® family, a six-lane fill and seal packaging machine for on-demand production of V-Shapes® unique single-dose sachets. This compact, professional-grade system features high quality synchronized printing on both sides all in one.

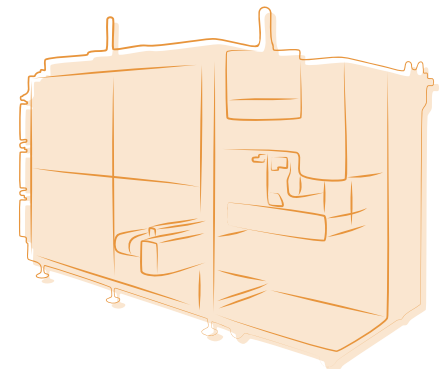

alpha

The **Alpha** is a fully-automatic, multi-lane vertical form, fill & seal machine can work across multiple products in any industry.

With a wide range of filling volumes and customizable dimensions available, the **Alpha** also stands out for its small, compact footprint and modular system. The attractive, modern design houses a core of best-in-class technology and the latest generation components. Brushless motor technology and accurate brushless motor dosing systems prevent costly overfilling on volumes from 0.2 ml to 38 ml.

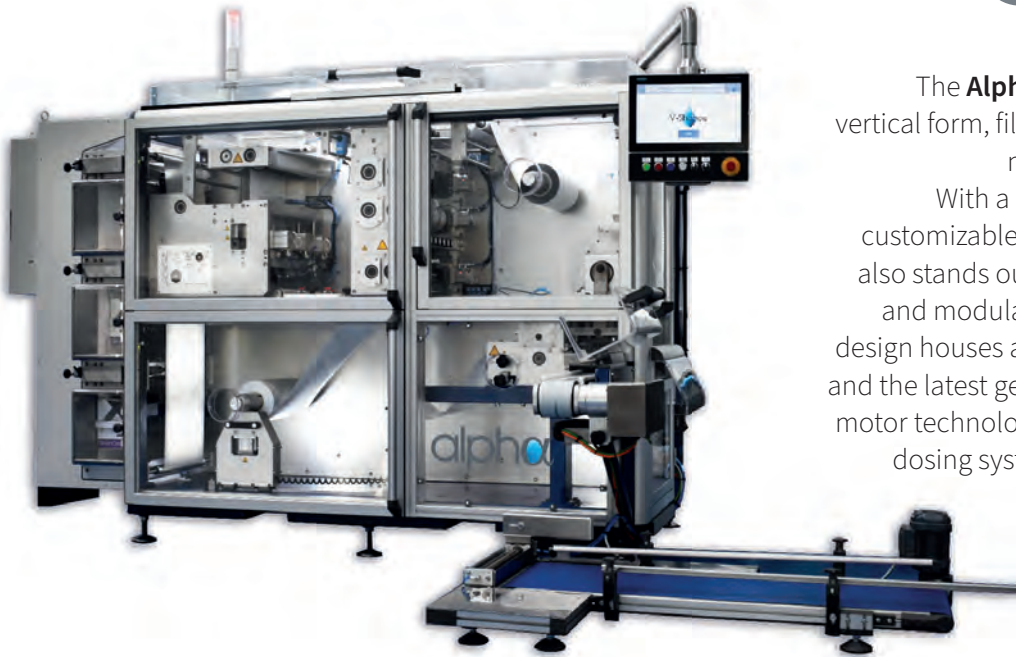

Average output

Up to 16,000 units per hour



Easy change set

Changeover time under 30 minutes



Adaptable

To any industry: Pharmaceutical, Cosmetic, Food and Chemical

Alpha machine special features

- ⊗ Touch screen control operator panel 15" (HMI) with integrated recipe management
- ⊗ Up to 6 fill, form and seal lanes depending on sachet size
- ⊗ Welding station for vertical and horizontal sealing with electronically controlled temperature system
- ⊗ Integrated marking and coding unit for thermal transfer print in line of the bottom side
- ⊗ Production management with pieces counter
- ⊗ 6 flow sensors for automatic flow control at speed change
- ⊗ Integrated marking and coding
- ⊗ End of line pouch die-cutting group, with pneumatic system to control sachets output

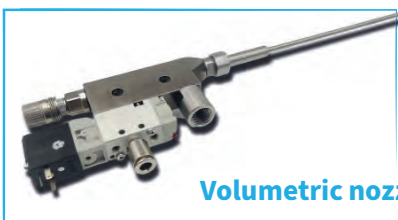

Volumetric nozzle

Volumetric pump

This system is capable of dosing fluids with low/medium viscosity with quantities ranging from 1-15ml with a sensitivity of 0.2gr



Prime

Prime automatic packaging machine for patented V-Shapes® one hand opening sachets is distinctive for its reduced dimensions and compact modular system.

The design of this machine conforms with the Good Manufacturing Practice standards and it has an advanced patented system of micrometric incision with pneumatic drive.

Easy, intuitive operator interface. V-Shapes® supplies to you an end-to-end solution for all your production needs from materials supplies to software update.



High precision dosing system

Automatic conveyor for the finished sachets collection

Intuitive 7" touch panel



Average output

Up to 2,100 unit per hour



Easy to operate

Single operator and intuitive 7" touch screen



High ROI

Great Return On Investment for small medium productions

Prime machine special features



Compact vertical/horizontal sealing + filling area, easy adjustable upon format changes. Integrated Videojet TTO coder for variables printing.



Patented internal and external pre-cut system adjustable with micrometer screws for V-Shapes® one hand unit-dose opening solution.

2 liters overpressurized stainless steel hopper with easy cleaning system for a quick change of the product.





A powerful compact single pass print solution integrable with V-Shapes® packaging machines

VS dflex reel-to-reel nearline printer takes advantage of speed and image quality from the partnership with the main suppliers like Memjet® and ColorGATE® which offer their water-based pigment inks, and advanced features and color management to realize a solution to rapidly print and package a fully customized sachet starting from the white reels of films till the final boxing in a reduced area. The combination of world best suppliers and the V-Shapes® Alpha packaging machine allows you to have in a minimal space a LEAN production and fast delivery of V-Shapes® unit-dose sachet with the innovative one hand opening system.



Reduced costs

For material and production



Cloud connectivity

Seamlessly integrates with ColorGATE Productionserver



High quality printing

1600x1600 dpi at speeds up to 27,4 m/min

VS dflex special features

With the latest digital printing technology, powered by Memjet Duraflex, **VS dflex** reach one of the lowest production costs on the market. Friendlier for the environment DuraFlex ink reduces production permit and waste handling costs. Combination of water based dye inks, high capability print heads, low amount of coating needed for high performance, reduce production cost.

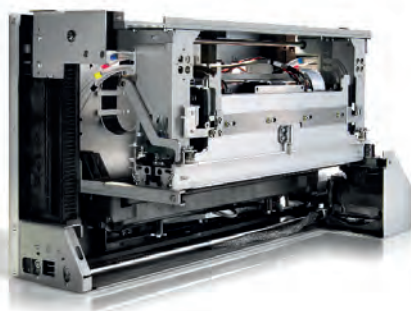

DuraFlex is the latest pigment-based, flexible and economical modular single-pass print system by Memjet®. Equipped with multicolor A3+ printhead to realize light productions and wide format solutions that enable printing with market-leading image quality, durability and speed.



Our fully-automatic, multi-lane vertical form, fill & seal machine Alpha, combined with Memjet Duraflex printing technology evolves, becoming **AlphaFlex**.

AlphaFlex, with integrated digital high resolution printing and buffer system, will reduce time to market and cost for short-medium production runs of the innovative V-Shapes® unit-dose packs. In only one machine all the expertise in packaging of V-Shapes® together with Memjet high quality printing solutions.



Patented opening cut created through micrometric engraving pneumatic actuation

Printing buffer to align the different speed of the printing module to the production phase



In line high quality design

With resolution up to 1600 x 1600 dpi



Maximum efficiency

Print and pack all in one at an incredible pace



Proprietary RIP Software

ColorGATE Productionserver enables printing workflow integration

AlphaFlex technical data

Printing speed

27.4 m/min (90 ft/min) or 45.7 m/min (150 ft/min)

Printing specs

made for high durability aqueous inkjet digital printing

Production details

equipped with printing buffer and 6 flow sensors for automatic flow control at speed change



Operating with Artysio green materials



with best sealing properties



suitable barrier performances



certified for V-Shapes® packaging machine



V-Shapes® sustainable material options

Thanks to the partnership with important companies like SIHL and ARTYSIO and their in-depth knowledge of functional films and recyclable polypropylene substrates V-Shapes is able to offer sustainable material alternatives granting great interaction with V-Shapes' machinability and packaging process.

Recyclable

reNEW X-100
reNEW X-500



Biobased



Compostable



Made of compostable material according to EN13432

Any size between 40mm and 100mm available

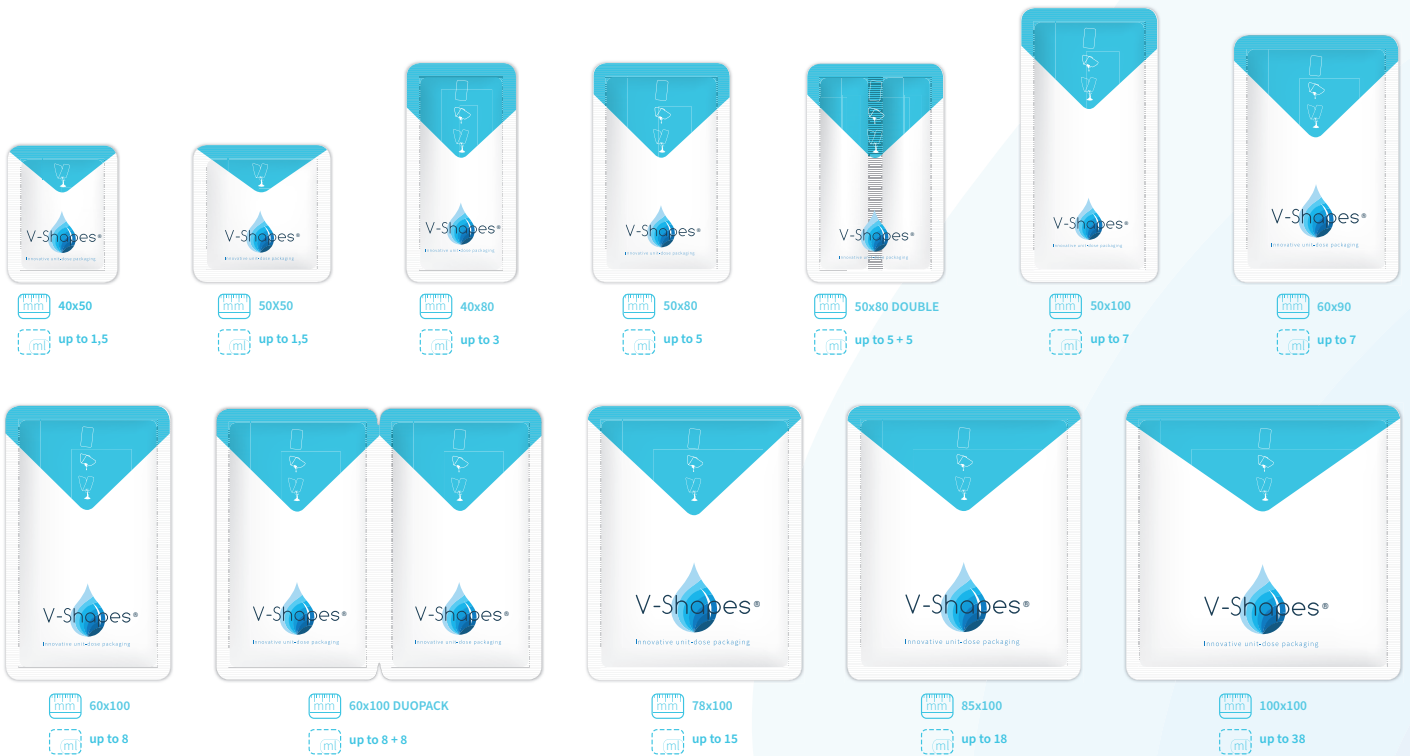

Opening pre-cut

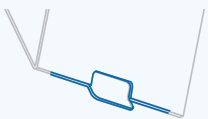

Squared opening pre-cut

Ideal shape to dispense and spread products over any surface

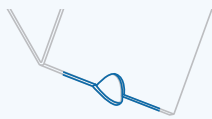

Half moon opening pre-cut

Standard opening for thick or dense products



Drop opening pre-cut

Special opening to dispense liquid products through drops

ONE SUPPLIER FOR ALL

V SERVICE V MATERIAL V EXPERTISE

SEAMLESSLY INTEGRATES WITH COLORGATE PRODUCTIONSERVER, AUTOMATICALLY PROCESS INCOMING JOBS



V-SHAPES® Srl | Via Persicetana, 20B - 40012 | Calderara di Reno (Bologna) | Italy | +39 051 0185079 | info@v-shapes.com

www.v-shapes.com

FOLLOW US: f in YouTube Twitter

MADE in ITALY



V-Shapes®

DISCOVER V-SHAPES® Srl



Cod. A2400