

TELESCOPIC HANDLER **ATTACHMENT GUIDE**



GEHL®

MARCH 2025



DYNATTACH®

- STANDARD ON ALL RS MODELS AND TH MODELS (EXCLUDING TH5-19)
- OPTIONAL ON ALL DL MODELS
- AUTOMATIC LATCHING SYSTEM - NO PINS TO LOOSE ON SITE
- NARROW DESIGN TO INCREASE OPERATOR VISION TO ATTACHMENT
- BEST FOR LIFT AND PLACE USE



DYNACARRIER®

- OPTIONAL ON DL MODELS AND TH MODELS (EXCLUDING TH5-19)
- A TOOL CARRIER TYPE ATTACHMENT SYSTEM
- WIDER DESIGN TO PROVIDE MORE SUPPORT FOR WIDER ATTACHMENTS
- MANUAL OR HYDRAULIC LOCKING SYSTEM AVAILABLE - NO PINS TO LOOSE ON THE SITE
- BEST FOR WIDER ATTACHMENT USE OR TOOL CARRIER USE



SKID STEER ATTACH

- STANDARD ON TH5-19, GCT 3-14 AND GCT 3-14+



TABLE OF CONTENTS

3	-----	STANDARD SHAFT FORK CARRIAGES
4	-----	ROTATING SHAFT FORK CARRIAGES
5	-----	SIDE SHIFT CARRIAGES
6	-----	FORK SHIFT CARRIAGES
7	-----	SWING CARRIAGES
8	-----	LOG AND PIPE GRAPPLE
9	-----	BUCKETS - LIGHT MATERIAL
10	-----	BUCKETS - SCRAP
11	-----	TRUSS BOOMS
12	-----	TRUSS BOOMS WITH WINCH
13	-----	AUGER DRIVE
14	-----	WORK PLATFORM - STANDARD
15	-----	LIFTING SHACKLE
16	-----	PIPE GRAPPLE
17	-----	LIFTING HOOK
18	-----	UNIVERSAL SKID STEER MOUNT
19	-----	BLOCK FORKS
20	-----	LUMBER FORKS
21	-----	PALLET FORKS
22	-----	FORK-MOUNTED TRASH BIN



TELESCOPIC HANDLER ATTACHMENT GUIDE STANDARD SHAFT FORK CARRIAGES

TELESCOPIC HANDLER ATTACHMENT GUIDE ROTATING SHAFT FORK CARRIAGES

**NOTE: REQUIRES AUXILIARY
HYDRAULIC BOOM LINES**

i TECHNICAL INFORMATION

- STANDARD SHAFT FORK CARRIAGES WITH 2.0" OR 2.5" DIAMETER SHAFTS
- SHAFT-MOUNTED IN FRAME SLOTS – ALLOW FOR UP TO 3" OF VERTICAL SHAFT ADJUSTMENT FOR PLACING LOADS ON UNEVEN SURFACES
- BACKREST IS 36" TALL
- CENTER VERTICAL SUPPORT IS 1.5" WIDE, SO SMALLEST POSSIBLE DISTANCE BETWEEN FORKS IS 1.5"



i TECHNICAL INFORMATION

- ROTATING SHAFT FORK CARRIAGES WITH 2.0" OR 2.5" DIAMETER SHAFTS
- SHAFT-MOUNTED IN FRAME SLOTS – ALLOW FOR UP TO 3" OF VERTICAL SHAFT ADJUSTMENT FOR PLACING LOADS ON UNEVEN SURFACES
- BACKREST IS 36" TALL
- HYDRAULIC POWERED CYLINDER ROTATES LOAD 10 DEGREES TO LEFT OR RIGHT
- THIS CYLINDER IS MOUNTED ON THE RIGHT SIDE OF THE FRAME TO MAXIMIZE OPERATOR VISIBILITY TO THE FORKS
- DUE TO CENTER PIVOT FOR CARRIAGE ROTATION, MINIMUM FORK DISTANCE IS 4" BETWEEN FORKS



COMPATIBILITY

DYNATTACH®

PART NUMBER	NR20347	NR20348	805375	805501	804978	804979	NR20261	807359	807361	NR20351
DESCRIPTION	48" wide	66" wide	48" wide	66" wide	48" wide	66" wide	72" wide	48" wide	66" wide	72" wide
SHAFT SIZE	2"	2"	2"	2"	2"	2"	2"	2.5"	2.5"	2.5"
MODELS										
RS5-19	X	X								
RS6-34			X	X						
RS6-42					X	X	X			
TH6-42					X	X	X			
RS8-42					X	X	X			
TH8-42					X	X	X			
RS8-44					X	X	X			
RS9-50					X	X				
RS10-44					X	X	X			
RS10-55					X	X	X			
TH10-55					X	X	X			
RS12-42								X	X	X
TH12-42								X	X	X
TH12-55								X	X	X
DL-7										
DL-9					X	X	X			
DL11-44								X	X	X
DL11-55								X	X	X
DL12-40								X	X	X
DL12-55								X	X	X
TH10-55								X	X	X
TH12-42								X	X	X

DYNACARRIER®

PART NUMBER	806062	806417	NR20262	807358	807360	NR20362
DESCRIPTION	48" wide	66" wide	72" wide	48" wide	66" wide	72" wide
SHAFT SIZE	2"	2"	2"	2.5"	2.5"	2.5"
MODELS						
DL-7	X	X	X			
DL-9	X	X	X			
DL11-44				X	X	X
DL11-55				X	X	X
DL12-40				X	X	X
DL12-55				X	X	X
TH10-55				X	X	X
TH12-42				X	X	X

COMPATIBILITY

DYNATTACH®

PART NUMBER	NR20355	NR20356	805502	805503	804614	804616	NR20123	NR20124
DESCRIPTION	48" wide	66" wide	48" wide	66" wide	48" wide	66" wide	48" wide	66" wide
SHAFT SIZE	2"	2"	2"	2"	2"	2"	2.5"	2.5"
MODELS								
RS5-19	X	X						
RS6-34			X	X				
RS6-42					X	X		
TH6-42					X	X		
RS8-42					X	X		
TH8-42					X	X		
RS8-44					X	X		
RS9-50					X	X		
RS10-44					X	X		
RS10-55					X	X		
TH10-55					X	X		
RS12-42							X	X
TH12-42							X	X
DL-7					X	X		
DL-9					X	X		
DL11-44							X	X
DL11-55							X	X
DL12-40							X	X
DL12-55							X	X
TH10-55							X	X
TH12-55							X	X

DYNACARRIER®

PART NUMBER	807262	807263	NR20125	NR20126
DESCRIPTION	48" wide	66" wide	48" wide	66" wide
SHAFT SIZE	2"	2"	2.5"	2.5"
MODELS				
RS12-42			X	X
TH12-42			X	X
DL-7	X	X		
DL-9	X	X		
DL11-44			X	X
DL11-55			X	X
DL12-40			X	X
DL12-55			X	X
TH10-55			X	X
TH12-55			X	X



TELESCOPIC HANDLER ATTACHMENT GUIDE SIDE SHIFT CARRIAGES

**NOTE: REQUIRES AUXILIARY
HYDRAULIC BOOM LINES**

i TECHNICAL INFORMATION

- SIDE-SHIFTING SHAFT TYPE FORK CARRIAGE WITH 2.0" DIAMETER SHAFT
- SHAFT-MOUNTED IN FRAME SLOTS – ALLOW FOR UP TO 3" OF VERTICAL SHAFT ADJUSTMENT FOR PLACING LOADS ON UNEVEN SURFACES
- HYDRAULIC POWERED CYLINDER MOVES FORK CARRIAGE UP TO 4.0" LEFT OR RIGHT
- CYLINDER IS MOUNTED ON RIGHT FRAME TO MAXIMIZE OPERATOR VISIBILITY TO FORKS
- BACKREST IS 36" TALL
- CENTER VERTICAL SUPPORT IS .75" WIDE, SO SMALLEST POSSIBLE DISTANCE BETWEEN FORKS IS .75"



COMPATIBILITY

DYNATTACH®

PART NUMBER	50860090
DESCRIPTION	48" wide
SHAFT SIZE	2"
MODELS	
RS5-19	X
RS6-34	X

TELESCOPIC HANDLER ATTACHMENT GUIDE FORK SHIFT CARRIAGES

**NOTE: REQUIRES AUXILIARY
HYDRAULIC BOOM LINES**

i TECHNICAL INFORMATION

- SINGLE FORK POSITIONING SHAFT FORK CARRIAGES WITH 2.0" DIAMETER SHAFTS
- HYDRAULIC POWERED CYLINDER MOVES LEFT FORK TO ALLOW CORRECT FORK SPACING FOR MULTIPLE PALLET SIZES. OPERATOR ALIGNS RIGHT FORK WITH PALLET AND THEN USES THE HYDRAULIC AUXILIARY FUNCTION TO MOVE THE LEFT FORK INTO CORRECT POSITION.
- BACKREST IS 44" TALL
- LEFT FORK MOVEMENT IS UP TO 16.75" ON 50" WIDE AND 26.25" ON 72" WIDE



COMPATIBILITY

DYNATTACH®

PART NUMBER	50841776	50841775	50860225
DESCRIPTION	50" wide	50" wide	72" wide
SHAFT SIZE	2"	2"	2.5"
MODELS			
RS5-19	X		
RS6-34	X		
RS6-42		X	
TH6-42		X	
RS8-42		X	
TH8-42		X	
RS8-44		X	
RS10-44		X	
RS10-55		X	
TH10-55		X	
RS12-42			X
TH12-42			X
DL-7		X	
DL-9		X	
DL11-44			X
DL12-55			X
TH12-55			X

DYNACARRIER®

PART NUMBER	N820524
DESCRIPTION	48" wide
SHAFT SIZE	2"
MODELS	
DL-7	X
DL-9	X



TELESCOPIC HANDLER ATTACHMENT GUIDE

SWING CARRIAGES

NOTE: REQUIRES AUXILIARY HYDRAULIC BOOM LINES

i TECHNICAL INFORMATION

- SHAFT FORK CARRIAGES WITH 2.0" DIAMETER SHAFTS
- HYDRAULIC POWERED CYLINDER CONTROLS PIVOT OF FORK CARRIAGE TO LEFT OR RIGHT - ALLOWS OPERATORS TO SWING THE LOADS OFF CENTER FOR PLACEMENT IN OPEN WINDOWS OR TO THE SIDE OF THE MACHINE.
- ANGLE OF PIVOT/SWING IS CONTROLLED WITH HYDRAULIC AUXILIARY BOOM FUNCTION
- 90 DEGREE TOTAL IS 45 DEGREES LEFT/RIGHT OF CENTER
- 180 DEGREE TOTAL IS 90 DEGREES LEFT/RIGHT OF CENTER
- BACKREST IS 45" TALL
- PN 807105 IS 66" WIDE, PN 50860041 IS 66" WIDE



COMPATIBILITY

DYNATTACH®		
PART NUMBER	807105	50860041
DESCRIPTION	90 degree	180 degree
SHAFT SIZE	2"	2"
MODELS		
RS6-42	X	X
TH6-42	X	X
RS8-42	X	X
TH8-42	X	X
RS8-44	X	X
RS10-55	X	
TH10-55	X	
RS12-42	X	X
TH12-42	X	X
DL-7	X	X
DL-9	X	X
DL11-44	X	X
DL11-55	X	
DL12-40	X	X
DL12-55	X	
TH12-55	X	

TELESCOPIC HANDLER ATTACHMENT GUIDE

LOG AND PIPE GRAPPLE

NOTE: REQUIRES AUXILIARY HYDRAULIC BOOM LINES

i TECHNICAL INFORMATION

- SHAFT FORK CARRIAGES WITH SINGLE, COUNTER MOUNTED, HYDRAULIC OPERATED HOLD DOWN
- DESIGNED FOR USE WITH LONG, LARGE DIAMETER OBJECTS. HYDRAULIC POWERED CENTER HOLD DOWN IS USED TO HOLD OBJECTS ON FORKS.
- BACKREST IS 32" TALL AND GRAPPLE PIN HEIGHT IS 33"
- INCLUDES 60" X 5" X 2" PALLET FORKS RATED AT 10,000 LBS.
- MAXIMUM OPEN IS 57" FROM TOP OF FORK TO TIP OF GRAPPLE.
- MINIMUM CLOSE IS 7.6" FROM GRAPPLE TO BACKREST WITH GRAPPLE TIPS BELOW FORKS.



COMPATIBILITY

DYNATTACH®	
PART NUMBER	806434
DESCRIPTION	78" wide
SHAFT SIZE	2"
MODELS	
RS6-42	X
TH6-42	X
RS8-42	X
TH8-42	X
RS8-44	X
RS10-44	X
RS10-55	X
TH10-55	X
RS12-42	X
TH12-42	X
DL-7	X
DL-9	X
DL11-44	X
DL11-55	X
DL12-40	X
DL12-55	X
TH12-55	X

DYNACARRIER®	
PART NUMBER	806073
DESCRIPTION	78" wide
SHAFT SIZE	2"
MODELS	
DL-7	X
DL-9	X
DL11-44	X
DL11-55	X
DL12-40	X
DL12-55	X
TH10-55	X
TH12-55	X



TELESCOPIC HANDLER ATTACHMENT GUIDE
BUCKETS - LIGHT MATERIAL

TELESCOPIC HANDLER ATTACHMENT GUIDE
BUCKETS - SCRAP

**NOTE: REQUIRES AUXILIARY
 HYDRAULIC BOOM LINES**

i TECHNICAL INFORMATION

- WELDED CUTTING EDGE FOR 820313, 808141, 808142
- BOLT-ON CUTTING EDGE FOR 806067 IS L69167 AND FOR 820005 IS 100341

i TECHNICAL INFORMATION

- BUCKET IS 45" DEEP AND 67" TALL
- BOLT-ON REVERSIBLE CUTTING EDGE PN 820493
- MAXIMUM CAPACITY 1.75 CUBIC YARD
- HYDRAULIC OPERATED GRAPPLE



COMPATIBILITY

DYNATTACH®

PART NUMBER	N820313	808141	808142
DESCRIPTION	1.0 yd ³	1.3 yd ³	1.3 yd ³
SHAFT SIZE	71" wide	96" wide	96" wide
MODELS			
RSS-19	X		
RS6-34		X	
RS6-42			X
TH6-42			X
RS8-42			X
TH8-42			X
RS8-44			X
RS10-44			X
RS10-55			X
TH10-55			X
RS12-42			X
TH12-42			X
DL-7			X
DL-9			X
DL11-44			X
DL11-55			X
DL12-40			X
DL12-55			X
TH12-55			X

DYNACARRIER®

PART NUMBER	806067	N820005
DESCRIPTION	1.3 yd ³	2.0 yd ³
SHAFT SIZE	96" wide	100" wide
MODELS		
DL-7	X	X
DL-9	X	X
DL11-44	X	X
DL11-55	X	
DL12-40	X	X
DL12-55	X	
TH10-55	X	
TH12-55	X	

COMPATIBILITY

DYNACARRIER®

PART NUMBER	N820279
DESCRIPTION	96" wide
MODELS	
DL-7	X
DL-9	X
DL11-44	X
DL12-40	X
TH12-42	X



TELESCOPIC HANDLER ATTACHMENT GUIDE TRUSS BOOMS

TELESCOPIC HANDLER ATTACHMENT GUIDE TRUSS BOOMS WITH WINCH

**NOTE: REQUIRES AUXILIARY
HYDRAULIC BOOM LINES**

i TECHNICAL INFORMATION

- DESIGNED FOR USE WITH SUSPENDED LOADS
- QUICK ATTACH MOUNTED WITH EXTENDED HORIZONTAL REACH TO AID IN LOAD PLACEMENT
- A PINTLE HOOK AT THE END OF THE ATTACHMENT PROVIDES A POSITIVE RETENTION METHOD FOR CHAINS OR STRAPS TO THE SUSPENDED LOAD. A PINTLE HOOK IS FORGED STEEL WITH A 1.88" INNER EYE AND INCLUDES A CHAINED LOCKING COTTER PIN.
- MAXIMUM CAPACITY FOR THE ATTACHMENT IS LISTED; HOWEVER, THE MACHINE LOAD CHART SHOULD BE USED TO DETERMINE THE CORRECT CAPACITY FOR THE ATTACHMENT BASED ON THE POSITION OF THE BOOM AND MACHINE.
- REFER TO THE OPERATOR'S MANUAL FOR FURTHER INFORMATION ON OPERATING THE TELESCOPIC HANDLER WITH SUSPENDED LOADS.

i TECHNICAL INFORMATION

- QUICK ATTACH MOUNTED WITH EXTENDED HORIZONTAL REACH TO AID IN LOAD PLACEMENT OF SUSPENDED LOADS
- A PINTLE HOOK AT THE END OF THE ATTACHMENT PROVIDES A POSITIVE RETENTION METHOD FOR CHAINS OR STRAPS TO THE SUSPENDED LOAD. A PINTLE HOOK IS FORGED STEEL WITH A 1.88" INNER EYE AND INCLUDES A CHAINED, LOCKING COTTER PIN.
- HYDRAULIC POWERED WINCH WITH 3/8" DIAMETER, 6 X 37 RIGHT REGULAR LAY IMPROVED PLOW STEEL CABLE. MAXIMUM LINE SPEED IS APPROXIMATELY 30 FT./MIN. THE WINCH INCLUDES A SPRING-APPLIED, HYDRAULIC RELEASE BRAKE.
- MAXIMUM CAPACITY FOR THE ATTACHMENT IS LISTED; HOWEVER, THE MACHINE LOAD CHART SHOULD BE USED TO DETERMINE THE CORRECT CAPACITY FOR THE ATTACHMENT BASED ON THE POSITION OF THE BOOM AND MACHINE.
- REFER TO THE OPERATOR'S MANUAL FOR FURTHER INFORMATION ON OPERATING THE TELESCOPIC HANDLER WITH SUSPENDED LOADS.



COMPATIBILITY

DYNATTACH®

PART NUMBER	N820312	805505	N804604	804536
DESCRIPTION	5' Truss	8' Truss	12' Truss	15' Truss
MAX. CAPACITY	2,000 lbs.	2,000 lbs.	2,000 lbs.	2,000 lbs.
MODELS				
RS5-19	X			
RS6-34		X		
RS6-42			X	
TH6-42			X	
RS8-42				X
TH8-42				X
RS8-44				X
RS10-44				X
RS10-55				X
TH10-55				X
RS12-42				X
TH12-42				X
DL-7			X	X
DL-9			X	X
DL11-44			X	X
DL11-55			X	X
DL12-40			X	X
DL12-55			X	X
TH12-55			X	X

DYNACARRIER®

PART NUMBER	806316	807393
DESCRIPTION	12' Truss	15' Truss
MAX. CAPACITY	2,000 lbs.	2,000 lbs.
MODELS		
DL-7	X	X
DL-9	X	X
DL11-44	X	X
DL11-55	X	X
DL12-40	X	X
DL12-55	X	X
TH10-55	X	X
TH12-55	X	X

COMPATIBILITY

DYNATTACH®

PART NUMBER	805504	N804605	807572	807574
DESCRIPTION	5' Truss	5' Truss	12' Truss	15' Truss
CABLE LENGTH	60 feet	60 feet	100 feet	100 feet
MAX. CAPACITY	3,000 lbs.	3,000 lbs.	2,000 lbs.	2,000 lbs.
MODELS				
RS6-34	X			
RS6-42		X	X	
TH6-42		X	X	
RS8-42		X		X
TH8-42		X		X
RS8-44		X		X
RS10-44		X		X
RS10-55		X		X
TH10-55		X		X
RS12-42		X		X
TH12-42		X		X
DL-7		X	X	X
DL-9		X	X	X
DL11-44		X	X	X
DL11-55		X	X	X
DL12-40		X	X	X
DL12-55		X	X	X
TH12-55		X	X	X

DYNACARRIER®

PART NUMBER	806074	807573	807575
DESCRIPTION	5' Truss	12' Truss	15' Truss
CABLE LENGTH	60 feet	100 feet	100 feet
MAX. CAPACITY	3,000 lbs.	2,000 lbs.	2,000 lbs.
MODELS			
DL-7	X	X	X
DL-9	X	X	X
DL11-44	X	X	X
DL11-55	X	X	X
DL12-40	X	X	X
DL12-55	X	X	X
TH12-55	X	X	X



TELESCOPIC HANDLER ATTACHMENT GUIDE AUGER DRIVE

**NOTE: REQUIRES AUXILIARY
HYDRAULIC BOOM LINES**

i TECHNICAL INFORMATION

- HYDRAULIC-POWERED AUGER WITH 2 9/16" ROUND SHAFT
- OPTIONS INCLUDE 50" LONG 9", 12" AND 18" DIAMETER BITS OR 14" LONG EXTENSION



COMPATIBILITY

DYNATTACH®

PART NUMBER	820312	805505	804604	804536
DESCRIPTION	5' Truss	8' Truss	12' Truss	15' Truss
MAX. CAPACITY	2,000 lbs.	2,000 lbs.	2,000 lbs.	2,000 lbs.
MODELS				
RS5-19	X			
RS6-34		X		
RS6-42			X	
TH6-42			X	
RS8-42				X
TH8-42				X
RS8-44				X
RS10-44				X
RS10-55				X
TH10-55				X
RS12-42				X
TH12-42				X
DL-7			X	X
DL-9			X	X
DL11-44			X	X
DL11-55			X	X
DL12-40			X	X
DL12-55			X	X
TH12-55			X	X

DYNACARRIER®

PART NUMBER	806316	807393
DESCRIPTION	12' Truss	15' Truss
MAX. CAPACITY	2,000 lbs.	2,000 lbs.
MODELS		
DL-7	X	X
DL-9	X	X
DL11-44	X	X
DL11-55	X	X
DL12-40	X	X
DL12-55	X	X
TH12-55	X	X

TELESCOPIC HANDLER ATTACHMENT GUIDE WORK PLATFORM - STANDARD

i TECHNICAL INFORMATION

- REQUIRES PWP SYSTEM FOR USE
- MOUNTS ON STANDARD FORK CARRIAGE WITH LOCKING PINS TO SECURE PLACEMENT
- FEATURES SWING GATES ON BOTH SIDES
- RAILINGS CAN BE REMOVED FOR EASE OF TRANSPORT
- CONFORMS TO NEW ANSI B56.6 2017 STANDARD
- 4' WIDE AND 9.5' LONG



COMPATIBILITY

FORK MOUNTED

PART NUMBER	N820147
MODELS	
RS6-34	X
RS6-42	X
TH6-42	X
RS8-42	X
TH8-42	X
RS8-44	X
RS10-44	X
RS10-55	X
TH10-55	X
RS12-42	X
TH12-42	X
DL-7	X
DL-9	X
DL11-44	X
DL11-55	X
DL12-40	X
DL12-55	X
TH12-55	X



TELESCOPIC HANDLER ATTACHMENT GUIDE

LIFTING SHACKLE

TELESCOPIC HANDLER ATTACHMENT GUIDE

PIPE GRAPPLE

NOTE: REQUIRES AUXILIARY HYDRAULIC BOOM LINES

i TECHNICAL INFORMATION

- A SECURE LIFTING POINT FOR MOVING SUSPENDED LOADS
- LIFT SHACKLE MAY BE USED WITH OR WITHOUT ATTACHMENTS MOUNTED
- LIFT SHACKLE HAS SAME CAPACITY LOAD CHART AS STANDARD FORK ATTACHMENT FOR SPECIFIED MACHINE
- LIFT SHACKLE IS STANDARD EQUIPMENT STARTING WITH RS5-19 RS519YK52245
- FOR EARLIER MODELS, FIELD UPDATE KIT PN 50321502 CAN BE ORDERED



i TECHNICAL INFORMATION

- FIXED FORKS WITH TWIN ARM HYDRAULIC-POWERED HOLD DOWNS
- FORKS ARE 60" X 2.25" X 6"
- MAXIMUM CAPACITY 10,000 LBS.
- DESIGNED FOR USE WITH PIPE UP TO 20" DIAMETER
- MAXIMUM OPENING FOR HYDRAULIC HOLD DOWNS IS 90 DEGREES



COMPATIBILITY

DYNATTACH®	
DESCRIPTION	Lift Shackle
MODELS	
RS5-19	X
RS6-34	X

COMPATIBILITY

DYNACARRIER®	
PART NUMBER	50860112
DESCRIPTION	96" wide
MODELS	
RS12-42	X
TH12-42	X
DL12-40	X



i ■ ■ **TECHNICAL INFORMATION**

- A SECURE LIFTING POINT FOR MOVING SUSPENDED LOADS
- LIFT HOOK MAY BE USED WITH OR WITHOUT ATTACHMENTS MOUNTED
- LIFT HOOK HAS SAME CAPACITY LOAD CHART AS STANDARD FORK ATTACHMENT FOR THE RESPECTIVE MACHINE
- INCLUDES SPRING CLOSING LATCH



i ■ ■ **TECHNICAL INFORMATION**

- MOUNTS TO DYNATTACH® AND PROVIDES A SECURE ATTACHMENT POINT FOR MOUNTING UNIVERSAL SKID STEER ATTACHMENT
- THIS ATTACHMENT IS NOT DESIGNED FOR USE WITH SKID STEER ATTACHMENTS WHICH WILL PLACE EXCESSIVE LOADS ON THE MACHINE OR COUPLERS, SUCH AS GROUND OR PILE ENGAGEMENT. IT IS NOT DESIGNED FOR USE WITH ATTACHMENTS WITH REQUIRE HIGH AND/OR CONTINUOUS AUXILIARY HYDRAULIC FLOW.
- THE WEIGHT OF THE SKID STEER ATTACHMENT USED WITH THE ADAPTER MOUNT IS ALSO RESTRICTED TO BELOW 1,000 LBS. (453 KG)



■ ■ ■ ■ ■ **COMPATIBILITY**

DYNATTACH®		
PART NUMBER	50860110	50860105
MODELS		
RS6-42	X	
TH6-42	X	
RS8-42	X	
TH8-42	X	
RS8-44	X	
RS10-44	X	
RS10-55		X
TH10-55		X
RS12-42	X	
TH12-42	X	
DL-7		X
DL-9		X
DL11-44		X
DL11-55		X
DL12-40		X
DL12-55		X
TH12-55		X

DYNACARRIER®	
PART NUMBER	50860105
MODELS	
DL-7	X
DL-9	X
DL11-44	X
DL11-55	X
DL12-40	X
DL12-55	X
TH12-55	X

■ ■ ■ ■ ■ **COMPATIBILITY**

DYNATTACH®	
PART NUMBER	50860218
DESCRIPTION	
	Skid Steer Adapter
MODELS	
RS5-19	X



TELESCOPIC HANDLER ATTACHMENT GUIDE BLOCK FORKS

TECHNICAL INFORMATION

- 2" x 2" square forks
- Available in 48" long only
- 2" pin for smaller machines
- 2 1/2" pin for 12,000+ lbs. machines

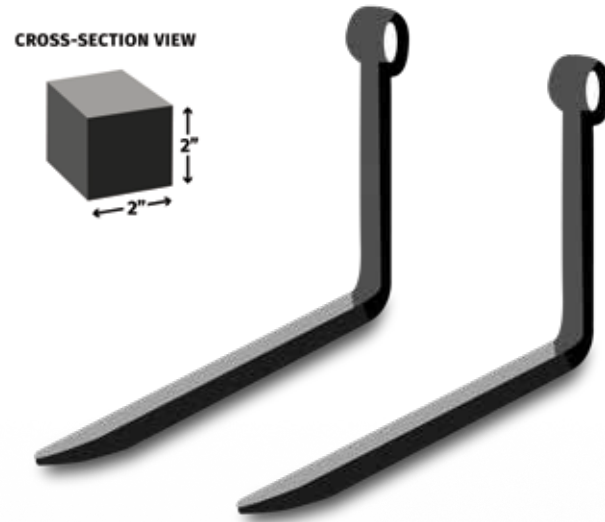

COMPATIBILITY

PART NUMBER	804602	N820428
DESCRIPTION	Set of 2	Set of 2
SHAFT SIZE	2" Wide	2.5" Wide
MODELS		
RS6-34	X	
RS6-42	X	
TH6-42	X	
RS8-42	X	
TH8-42	X	
RS8-44	X	
RS10-44	X	
RS10-55	X	
TH10-55	X	
RS12-42		X
TH12-42		X
DL12-55		X
TH12-55		X

Note: Capacity is 2,000lbs. per fork. Amount of forks must be adjusted based on capacity of machine.

TELESCOPIC HANDLER ATTACHMENT GUIDE LUMBER FORKS

TECHNICAL INFORMATION

- Forks with larger width and full taper
- Available in 60" long only
- 2" pin for smaller machines
- 2 1/2" pin for 12,000+ lbs. machines

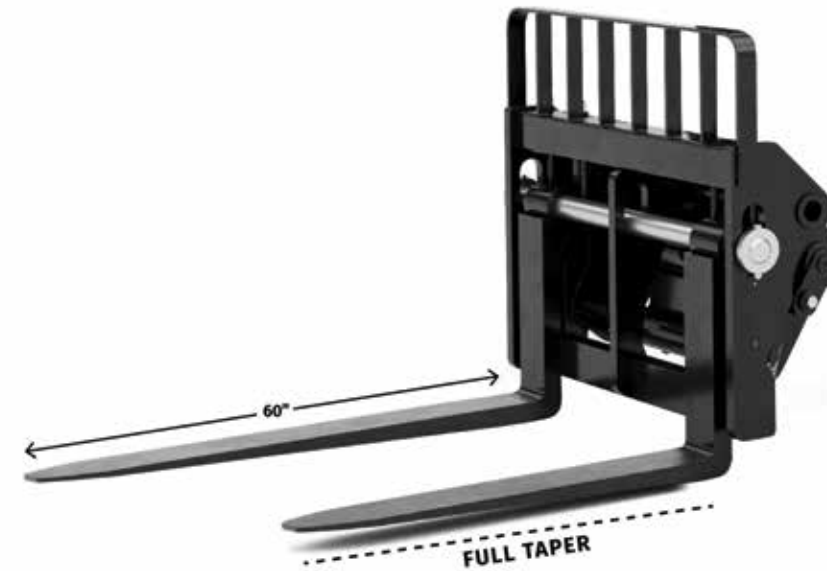

COMPATIBILITY

PART NUMBER	804485	N820468
SHAFT SIZE	2" Wide	2.5" Wide
MODELS		
RS6-34	X	
RS6-42	X	
TH6-42	X	
RS8-42	X	
TH8-42	X	
RS8-44	X	
RS10-44	X	
RS10-55	X	
TH10-55	X	
RS12-42		X
TH12-42		X
DL12-55		X
TH12-55		X



i ■ ■ ■ **TECHNICAL INFORMATION**

- 2" and 2 1/2" forks with 1/2 taper
- Available in 42", 48", 60" and 72" long



i ■ ■ ■ **TECHNICAL INFORMATION**

- 5,000lbs (2268kg) capacity
- Interior size of 5yd³ (3.8m³), overall dimensions of 4' x 5' x 7' (1.2m x 1.5m x 2.1m)
- Open front for easy accessibility to load and unload material
- Mounts to any RS or TH unit with Pallet or Lumber Forks
- Secure mounting with two locking pins and secondary system with chain behind fork carriage frame



■ ■ ■ ■ ■ **COMPATIBILITY**

2" WIDE FORKS

PART NUMBER	N820024	50841750	804401	860703	847282	N820363	847283	808453
X	42"	42"	48"	48"	48"	60"	60"	72"
SHAFT SIZE	2" Wide	2" Wide	2" Wide	2" Wide	2" Wide	2" Wide	2" Wide	2" Wide
MODELS								
RS5-19	X		X	X		X		
RS6-34	X		X	X	X	X	X	X
RS6-42	X		X	X	X	X	X	X
TH6-42	X		X	X	X	X	X	X
RS8-42	X		X	X	X		X	X
TH8-42	X		X	X	X		X	X
RS8-44	X		X	X	X		X	X
RS9-50		X			X		X	X
RS10-44					X		X	X
RS10-55					X		X	X
TH10-55					X		X	X
RS12-42					X		X	X
TH12-42					X		X	X
DL12-55					X		X	X
TH12-55					X		X	X

2 1/2" WIDE FORKS

PART NUMBER	807362	805333	N820469	807363	807364
X	48"	48"	48"	60"	72"
SHAFT SIZE	2.5" Wide	2.5" Wide	2.5" Wide	2.5" Wide	2.5" Wide
MODELS					
RS5-19					
RS6-34		X			
RS6-42		X			
TH6-42		X			
RS8-42		X			
TH8-42		X			
RS8-44		X			
RS9-50		X			
RS10-44		X			
RS10-55		X			
TH10-55		X			
RS12-42	X		X	X	X
TH12-42	X		X	X	X
DL12-55	X		X	X	X
TH12-55	X		X	X	X

■ ■ ■ ■ ■ **COMPATIBILITY**

PART NUMBER	50842169
FORK TYPE	Pallet or Lumber
MODELS	
RS6-34	X
TH6-42	X
TH8-42	X
TH10-55	X
TH12-42	X
TH12-55	X



GEHL[®]

WORKS LIKE YOU[™]

GEHL.COM



Manitou Equipment America, LLC

P.O. Box 179



One GEHL Way



West Bend, WI, USA 53095



P: (262) 334-9461

F: (262) 338-7517

Manitou Group reminds users to read and understand the operator's manual before operating any equipment. Also, make sure all safety devices and shields are in place and functioning properly. Manitou Group reserves the right to add improvements or make changes in specifications at any time without notice or obligation.

© 2025 Manitou Equipment America, LLC. All registered and unregistered marks are owned by Manitou Equipment America, LLC or its affiliates. All rights reserved.

® denotes registration in the United States. Trademarks may or may not be registered in other countries.